

**STUDENTS' DIFFICULTIES IN ONLINE SPEAKING LEARNING  
PROCESS ASSISTED BY WHATSAPP APPLICATION**

**SKRIPSI**

*Submitted in Partial Fulfillment of the Requirements  
for the Degree of Sarjana Pendidikan (S.Pd)  
English Education Program*

**By:**

**MISS NADIA NIYOM**  
**1802050124**



**FACULTY OF TEACHER' TRAINING AND EDUCATION  
UNIVERSITAS MUHAMMADIYAH SUMATERA UTARA**

**MEDAN**

**2023**



**MAJELIS PENDIDIKAN TINGGI**  
**UNIVERSITAS MUHAMMADIYAH SUMATERA UTARA**  
**FAKULTAS KEGURUAN DAN ILMU PENDIDIKAN**  
Jl. Kapten Mukhtar Basri No. 3 Medan 20238 Telp. 061-6622400 Ext. 22, 23,  
30

Website: <http://www.fkip.umsu.ac.id> E-mail: [fkip@umsu.ac.id](mailto:fkip@umsu.ac.id)

### BERITA ACARA

Ujian Mempertahankan Skripsi Sarjana Bagi Mahasiswa Program Strata 1  
Fakultas Keguruan dan Ilmu Pendidikan Universitas Muhammadiyah Sumatera Utara

بِسْمِ اللَّهِ الرَّحْمَنِ الرَّحِيمِ

Panitia Ujian Sarjana Strata-1 Fakultas Keguruan dan Ilmu Pendidikan dalam Sidangnya yang diselenggarakan pada hari Kamis, Tanggal 23 Februari 2023, pada pukul 08.30 WIB sampai dengan selesai. Setelah mendengar, memperhatikan dan memutuskan bahwa:

Nama : Miss Nadia Niyom  
NPM : 1802050124  
Program Studi : Pendidikan Bahasa Inggris  
Judul Skripsi : Students' Difficulties in Online Speaking Learning Process Assisted by WhatsApp Application

Dengan diterimanya skripsi ini, sudah lulus dari ujian Komprehensif, berhak memakai gelar Sarjana Pendidikan (S.Pd).

Ditetapkan : ( ) Lulus Yudisium  
( ) Lulus Bersyarat  
( ) Memperbaiki Skripsi  
( ) Tidak Lulus

#### PANITIA PELAKSANA

Ketua

  
Dra. Hj. Svamsuyurnita, M.Pd.

Sekretaris

  
Dr. Hj. Dewi Kesuma Nst, SS, M.Hum.

#### ANGGOTA PENGUJI:

1. Dr. Rakhmat Wahyuddin S, M.Hum
2. Rita Harisma, S.Pd., M.Hum
3. Rini Ekayati, S.S., M.A

1.

3.

2.

## SURAT PERNYATAAN

Assalamu'alaikum Warahmatullahi Wabarakaatuh

Saya yang bertandatangan dibawah ini :

Nama : Miss Nadia Niyom  
N P M : 1802050124  
Program Studi : Pendidikan Bahasa Inggris  
Judul Penelitian : Students' Difficulties in Online Learning Speaking Process Assisted by WhatsApp Application

Dengan ini saya menyatakan bahwa :

1. Penelitian yang saya lakukan dengan judul di atas belum pernah diteliti di Fakultas Keguruan dan Ilmu Pendidikan Universitas Muhammadiyah Sumatera Utara
2. Penelitian ini akan saya lakukan sendiri tanpa ada bantuan dari pihak manapun dengan kata lain penelitian ini tidak saya tempahkan (dibuat) oleh orang lain dan juga tidak tergolong plagiat
3. Apabila point 1 dan 2 di atas saya langgar maka saya bersedia untuk dilakukan pembatalan terhadap penelitian tersebut dan saya bersedia mengulang kembali mengajukan judul penelitian yang baru dengan catatan mengulang seminar kembali.

Demikian surat pernyataan ini saya perbuat tanpa ada paksaan dari pihak manapun juga, dan dapat dipergunakan sebagaimana mestinya.

Medan, January 2023

Hormat saya  
Yang membuat pernyataan

  
  
Miss Nadia Niyom

Diketahui oleh Ketua Program Studi  
Pendidikan Bahasa Inggris



**Pirman Ginting, S.Pd.,M.Hum.**



MAJELIS PENDIDIKAN TINGGI  
UNIVERSITAS MUHAMMADIYAH SUMATERA UTARA  
FAKULTAS KEGURUAN DAN ILMU PENDIDIKAN

Jl. Kapten Mukhtar Basri No. 3 Telp. (061) 6619056 Medan 20238  
Website : <http://www.fkip.umsu.ac.id> E-mail : [fkip@umsu.ac.id](mailto:fkip@umsu.ac.id)

LEMBAR PENGESAHAN SKRIPSI

بِسْمِ اللَّهِ الرَّحْمَنِ الرَّحِيمِ

Skripsi ini diajukan oleh mahasiswa di bawah ini

Nama : Miss Nadia Niyom  
N P M : 1802050124  
Program Studi : Pendidikan Bahasa Inggris  
Judul Penelitian : Students' Difficulties in Online Learning Speaking Process Assisted  
by WhatsApp Application

Sudah layak disidangkan

Medan, Januari 2023

Disetujui oleh:  
Pembimbing

  
**Rini Ekayati, S.S.,M.A.**

Diketahui oleh :

Dekan  
  
**Dr. Hj. Syamsuyurnita, M.Pd**

Ketua Program Studi  
  
**Pirman Ginting, S.Pd.,M.Hum.**

## ABSTRACT

**Miss Nadia Niyom. 1802050124. *Students' Difficulties in Online Speaking Learning Process Assisted by WhatsApp Application*. Skripsi. Faculty of Teacher Training and Education. Universitas Muhammadiyah Sumatera Utara. Medan. 2022**

The purpose of the study us to describes the students' difficulties in online speaking learning process assisted by WhatsApp Application. This research an explanation all the factors related to the method of qualitative research methods. Collected by interviewing respondents of English Education Program of Universitas Muhammadiyah Sumatera Utara. Data analysis are data reduction, data display and data conclusion drawing/verification. From the results of this research, it is that the showed difficulties of online speaking learning, first is about vocabulary such as lack of vocabulary, unfamiliar word, word meaning and the high level of vocabulary. The second is pronunciation such as accent of the speech and speech of fast.

***Keywords:*** *Online Speaking Learning, Students' Difficulties, WhatsApp, vocabulary, Pronunciation*

## ACKNOWLEDGEMENTS

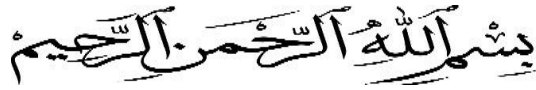

Assalamu'alaikum Warahmatullahi Wabarakatuh

Alhamdulillah, all praise is to Allah Subhanahu wa Ta'ala the most gracious and the most merciful who has given His guidance and blessings so that this study which as a partial fulfilment of the requirements in the graduation can be completed properly. This research titled *Students' Difficulties in Online Speaking Learning Process Assisted by WhatsApp Application*". Never forgotten for the blessings and greetings are also given to the prophet Muhammad who has brought all humans from the zahiliyah era to an era full of knowledge as it is today.

In completing this research, there were many obstacles that faced by the researcher. On this occasion she would like to delivered her deepest heart thanks to her beloved parents, Mrs. Aisyah Niyom, as the heroes in her life who always be there and support in every situation and condition such as for their prayers, material, courage and advice. Then for Armeenah Piyanart Niyom, Muneeroh Piyanut Niyom, Muhammad Jaensin Niyom and Hasan Songtham Niyom as her beloved siblings who are supporting and motivation to work hard every time.

There are so many people which have big impact for the researcher in finishing this study and thus the researcher would like to thank:

1. Prof. Dr. Agussani. M.AP. as the rector of Universitas Muhamadiyah Sumatera Utara.

2. Dra. Hj Syamsuyurnita, M.Pd as the Dean Faculty of Teachers' Training and Education of Universitas Muhammadiyah Sumatera Utara.
3. Pirman Ginting, S. Pd, M. Hum and Rita Harisma, S.H., M.Hum., as the head and secretary of English department for help in the process of completing the necessary requirements.
4. Rini Ekayati, S.S., M.A as her supervisor who already set available time to give the best guidance, suggestions and criticism during designing this study.
5. Muhammad Arifin, S.Pd., M.Pd as head of UMSU library that has provided her many references.
6. Yayuk Hayulina. M. S.Pd, M.Hum as her advisor.
7. All of English lecturers in UMSU who already transferred the knowledges and do the best efforts to all of the students in UMSU.
8. Her beloved closed friends, especially for Syahputri, Muhammad Syafii, Denisyah Triandini, Nurul Aina Tarigan, Sofia Rahmi Khaidir who always help her.
9. Friends in class C morning of English Department Program for the remarkable years at university
10. To all people who help her in finishing this study indirectly and can not be mention one by one.

Finally, expecting this study will be useful and give a beneficial to someone for academic fields. The researcher looks forward to the positive criticism and suggestion for the improvement of this research in the future.

Wasalamualaikum Warahmatullahi Wabarakatuh

Medan, January 2023  
Researcher

**Miss Nadia Niyom**  
**NPM: 1802050124**



## TABLE OF CONTENTS

<b>ABSTRACT .....</b>	<b>i i</b>
<b>ACKNOWLEDGEMENTS .....</b>	<b>i ii</b>
<b>TABLE OF CONTENTS .....</b>	<b>vi</b>
<b>LIST OF TABEL.....</b>	<b>viii</b>
<b>LIST OF FIGURE .....</b>	<b>ix</b>
<b>LIST OF APPENDIXS .....</b>	<b>x</b>
<b>CHAPTER I: INTRODUCTION</b>	
A. Background of the Study.....	1
B. Identification of the Problem.....	5
C. Scope and Limitation of the Study .....	6
D. Formulation of the Problems.....	6
E. Objectives of the Study .....	6
F. Significance of the Study.....	6
<b>CHAPTER II: LITERATURE REVIEW</b>	
A. Theoretical Framework .....	8
1. Difficulties Theory .....	8
2. The Concept Online Learning.....	10
3. The Difficulties on Online Learning .....	12
4. The Difficulties on Online Learning in Speaking Skill .....	14
5. Social Media .....	16

6. WhatsApp .....	18
B. Conceptual Framework .....	19
C. Previous Relevant Study .....	20

### **CHAPTER III: METHOD OF RESEARCH**

A. Research Design.....	24
B. Location of the Study .....	24
C. Source of Data .....	24
D. Technique of Collecting Data .....	25
E. Technique of Data Analysis .....	25

### **CHAPTER IV DATA AND DATA ANALYSIS**

A. Data .....	27
B. Data Analysis .....	28
C. Research Findings .....	34

### **CHAPTER V CONCLUSIONS AND SUGGESTIONS**

A. Conclusion .....	36
B. Suggestion .....	37

### **REFERENCES .....38**

### **APPENDIX .....41**

**LIST OF TABEL**

Table of Students' interviewed.....28

## **LIST OF FIGURE**

Figure 1 Diagram of Conceptual Framework.....	20
---	----

## **LIST OF APPENDIXS**

- Appendix A Instrument Wawancara
- Appendix B K1
- Appendix C K2
- Appendix D K3
- Appendix E Berita Acara Bimbingan Proposal
- Appendix F Berita Acara Seminar Proposal
- Appendix G Lembar Pengesahan Seminar Proposal
- Appendix H Surat Permohonan Izin Riset
- Appendix I Berita Acara Bimbingan Skripsi

# CHAPTER I

## INTRODUCTION

### **A. Background of the Study**

Nowadays, due to the pandemic, education is shifting to technological systems, replacing traditional face-to-face learning. This requires students' to improve their ability to use technology to support online courses, and students need an internet connection to successfully run their online classes. As long as the teacher or learner feels comfortable and enjoys the learning session by sharing files and tasks online, online learning is necessary to deliver the course. The coaching and getting to know landscape in Indonesia has modified a lot. This is caused by the Covid-19 (coronavirus disease) outbreak. Many areas of life have also been affected by this pandemic. For example, socially, economically, mainly in the educational sector. The Ministry of Education and Culture has announced a policy to implement teaching and learning processes in schools and colleges through online systems or e-learning. These circumstances forced students not only to master technology, but also to master technology for online learning. Also prepare the Internet contingent and their devices, as they will need to be connected to the lecture at the same time.

In this era, the technology is developing rapidly, (Costley, 2014) argues that "using technology to deepen student engagement in a meaningful, intellectually authentic curriculum makes a powerful contribution to learning." There are many applications that can support online learning, one of which is his

WhatsApp. WhatsApp is a simple, secure and reliable messaging application. Compared to other applications, WhatsApp application is the most popular and well-known application. This message application allows users to share media such as text her messages, chats, voice messages and videos with individuals or groups. WhatsApp supports group chats. This way you can talk to a group of friends, clubs or other groups. This makes WhatsApp Group easy to set up for online learning. There are pros and cons to using WhatsApp groups as a classroom learning medium. The advantages are easy access, low cost, and flexible study duration. The downside is limited internet access, but students can't focus as much on learning, learning is more theoretical, and there is no direct interaction with students, so little practice is required.

The four essential skills that need to be trained in English are speaking, listening, reading and writing. Speech plays a very important function these days in second/foreign dialect environments as a means of communication in everyday life. Among the four skills, speaking is the most important skill that students acquire. One of her key responsibilities of an educators who work with English-speaking students aim to help learners communicate effectively through oral conversation. Speaking is active or productive expertise. The four skills are equally important, but speech is the primary means communication. In other words, the purpose of language is to communicate, and the purpose of communication in a language environment is to communicate effectively. Speaking mastery also enables students to discuss directly with others. Communicating in English is not easy as it requires individuals to master multiple

aspects of speaking. fluency, vocabulary, pronunciation, grammar and comprehension.

Speaking is one of the 4 language studying abilities that scholars ought to master. These skills are directly related to all activities of daily life. It also works as a communication tool between students. (Woolf, 1980) He states that speaking has different meanings, which are as follows: by saying, saying, making known, or speaking. To declare; to announce; to proclaim; to celebrate; to use or be able to use (a particular language) when speaking and to address. Students can express their opinions, ideas, questions and receive information by speaking. (Burns, 1998) stated that “speaking is a combinatorial language skill”. According to (Chaney, 1998), “Speech is the process of constructing and sharing meaning using verbal and non-verbal symbols in various contexts. Speaking is an integral part of second language learning and teaching. This means that students must be able to communicate with others to obtain or exchange information and express their feelings. Speaking is considered the most difficult skill for most people as it simultaneously covers many aspects of English skills such as pronunciation, listening, grammar and vocabulary. (Yanto, 2015). When gaining knowledge of talking skills, college students want extra oral exercise in an effort to communicate extra confidently. Several gaining knowledge of strategies in talking instructions such as debates, discussions, seminars, storytelling, etc.

As language students who have learned English, Students should have the opportunity to work together orally in English. Unfortunately, when they actually taught and learned to speak in online learning, they had language problems.



Observations showed that students regularly had problems pronouncing English words. Also, my knowledge of English vocabulary and functional expressions was lacking, so I didn't know what to say. In addition, the students had grammar problems and could not speak or understand English fluently. (Wulandari Rian 2014:2). They seemed indifferent and shy to activities involving verbal skills. Many of them feared being criticized or embarrassed during online meetings in front of their friends.

By that definition, work is being done to allow large numbers of people to participate in similar virtual meetings, talk to each other, and provide recordings from anywhere with Internet access. Intended for use by organizations and various associations and distance learning, for educators working in schools and students studying at home, this is amazing in the current situation. (John Steven, 2020). With this app, teachers can share materials using Zoom highlights, so they can bring PPTs to meetings, but mobile phone issues or low specs may prevent all students from viewing them. The 2019 coronavirus disease (COVID-19) the epidemic has triggered a series of public health measures. E-learning tools play a vital role during this pandemic. However, in non-developed countries like Indonesia, there are technical, educational and financial problems. These issues can hinder the online learning process. For example, internet connectivity is poor, gadgets are scarce, and not all students and teachers have separate devices for web-based learning. Many of them are expected to share laptops and computers with their parents, sisters and brothers to get things done. (Subedi, et al. 2020:3).

Considering the results of the above presentation and the various situations today, it is difficult to use social media for learning, such as lack of diversification of e-learning courses, high availability of online teachers due to lack of e-learning experience. ethical issues such as lack of the right culture to apply this discipline, negative perceptions of e-learning, technical challenges such as slow internet speeds, lack of physical space in e-learning , supportive barriers such as lack of facilities, lack of permission to use cafeterias, lack of time, communication impairments such as classmates, assessment challenges such as students with virtual faculty leadership due to lack of face-to-face communication.

Based on the phenomenon above, the researcher was interested in conducting an exploratory study to research difficulties using of WhatsApp for English language students, and then interview students about their difficulties using of WhatsApp in online learning. Furthermore, social media use and encourages students to using WhatsApp to improve their English language skills. The researcher is interested in analyzing students' difficulties in online learning by conducting the following studies. Student difficulties in the online language learning process using WhatsApp.

## **B. Identification of the Problem**

1. The lack of network so that online learning has difficulty.
2. Problems or low specs on their mobile phones.
3. Students do not formally use WhatsApp for online learning.

### **C. Scope and Limitation of the Study**

The scope of this research is about students' difficulties in online speaking learning process at English department students. The limitation of this research is learning through WhatsApp in English Education Program students at Universitas Muhammadiyah Sumatera Utara.

### **D. Formulation of the Problem**

Against the background of the study, the research questions are: What difficulties do students face with online language learning via WhatsApp during the Covid-19 pandemic?

### **E. The Objectives of the Study**

Based on the research background, the purpose of the study is to describe the difficulties faced by students in online language learning via WhatsApp in the teaching and learning process.

### **F. The Significance of the Study**

#### 1. For Students

As extra information in studying students' difficulties in online learning via social media and adaptation to online learning in the epidemic situation. however with unique points of view.

#### 2. For teachers

This research can be used by specific English to give students perform tasks via WhatsApp in an online learning process.

### 3. For other readers or researchers

The research expects that the readers know how to solve problems in the online learning process via WhatsApp.

## **CHAPTER II**

### **LITERATURE REVIEW**

#### **A. Theoretical Framework**

This chapter presents the basic concepts as a theoretical framework for research, an explanation of some theories relate to the topic of those about difficulties in online learning process through WhatsApp.

##### **1. Difficulties Theory**

According to (Huang, 2002) the increasing difficulty in recognizing and responding to student emotions is one reason why a deeper understanding is needed as new technologies and increased class sizes impact education. Online learning environments, especially distance learning environments, are often explicitly designed to give students flexibility and autonomy in the classroom. When students study online or remotely, they can access materials that everyone has, centralized classes, and find their own source and time or place, constrained by her schedule.

Hounsell, (2007) the difficulty in directing attention to the epistemological challenges that students may face when working on assignments, especially in online learning, suggests the need to expand the concept of knowledge especially in online learning. There are some the potential difficulties in learning online because unfamiliar of cultural knowledge of online learning a great role understanding the system. Some difficulties faced by the student such as

the lack of network, understanding structure, unable to comprehend natural learning, lose confidence, maintaining concentration, bad recording, that factors causing students difficulty problem are categorized into different sources including problems related to the online learning, the problems related to task and learning activities.

Taking into account as now no longer all Indonesian college students stay in city areas, instructors need to determine to put in force the simplest and green technological gadgets or gadgets, systems, packages or platforms. The selection of inappropriate technology devices will only burden students, especially those with poor internet access. Moreover, choosing an inappropriate device or application or system will cost a lot of money which will trigger new problems for parents of students whose financial support has been affected by the pandemic. Therefore, both lecturers and education practitioners must really think about it wisely and fairly so that all students can get effective learning. This is certainly a challenge for lecturers and education practitioners.

Difficulties are things or distractions that cause students to fail or at least become distractions that can hinder their will to learn. According to Sabri, learning difficulties are students' difficulties in accepting or absorbing learning at school, that difficulty is a difficult situation to complete or do a job and learning difficulties are things or distractions that cause students to fail or at least become distractions that can hinder to learning difficulties are defined as anything that makes it difficult or prevents someone from learning, understanding, and mastering something to achieve goals. Difficulty in learning is characterized by

low or below average achievement, the results carried out are not balanced with the effort made and are slow in carrying out learning tasks. Another thing is marked by ignoring the assignments given by the teach. This difficulty in doing English assignments means not completing work or responsibilities given by someone due to several different factors.

The other difficulty in learning is to prepare the packaging of the material in such a simple and easy-to-understand way. Because the challenge discussed is in the learning class, the lecturer must be aware of providing material that is suitable for the needs of students learning through online learning. This step helps students more easily understand what is being said in English, there are many factors such as submission of required assignments, course materials, internet access and internet quotas. This can affect student engagement and participation during the online learning process.

However, (Bjork, 2011) stated that research has shown that a variety of factors, including academic ability, internet access, and the presence of technical issues in the online learning process, create difficulties that cause confusion and problems. Students may have to overcome misunderstandings before they can better understand the subject.

## **2. The Concept Online Learning**

Online gaining knowledge of is a part of the current machine of explaining faculty applications at the start of the brand new millennium. The idea of online learning is like an ever-changing culture. By comparison, it is difficult to find a

single concept of online learning that the majority of the research community can agree on. Specific professional views and alternatives are encouraged via way of means of unique understandings of online learning.

The Internet has become one of the most important means of making research and learning resources available so that both teachers and students can share information and learn. (Richard and Haya 2009:183). This means that the Internet has become one of the most important approaches to making resources available for exploration and learning, and making data shared and accessible to teachers and students. Technology-based e-learning uses the Internet and other key technologies to create materials and coordinate courses within units (Fry, 2001:223). This means that innovation-based e-learning embraces the use of the Internet and other important advances to create research, training and materials beyond the politics of courses within the Institute.

Online gaining knowledge of refers to the usage of communication and statistics era to offer get admission to to net gaining knowledge of/academic tools. In its broadest sense according to Maltz et al (2005), the term e-learning is used in various contexts such as distributed learning, online distance learning, and hybrid learning. This means that 'e-learning' is used in a variety of ways, including digital learning, online distance learning, and hybrid learning. The term online learning also applies, according to Wentling et al (2000), Acquisition and use of information that is primarily activated and transmitted electronically. They envision e-gaining knowledge of to be primarily based totally on gadgets and phones, but e-learning could evolve into platforms that incorporate various



technologies such as wireless, television, and mobile phones. This indicates that the term "online learning" refers primarily to the acquisition and use of information that is possible and communicated electronically. Liu and Wang (2009) a literature review on e-learning concepts reveals that e-learning processes are primarily characterized by being Internet-based. A global sharing and learning resource. Information exchange and knowledge flow through network courses. Finally, learning diversity is provided as a computer-generated learning environment to deal with distance and knowledge problems.

### **3. The Difficulties on Online Learning**

With the availability of online learning time and distance, more and more students are engaging in online education. However, many of them face major obstacles that prevent them from completing the course effectively. In some families, schools do not have necessary educational facilities such as computers and software. This problem of lack of material resources can be exacerbated when all school-aged children are at home and the family's only computer is not sufficient. Also, having different living rooms for each family member can reduce the chances of dropping out of school. Also, the lack of material support that can be important for homeschooling is concentrated among poor and low-income families. This means that families neglect important educational resources such as computers. This dilemma is more difficult for poor families whose children prefer to stay at home rather than go to school. There are many variations of living rooms for household members. This can limit your chances of completing your homework.

This is due to the lack of human interaction, the absence of teachers, and the inability to discuss things with peers, but students can often be upset, may be too small for students and require physical space to solve questions and practice with real resources. (Gamelearn 2019). Online classes can be customized for both educators and students, but such classes have their own set of problems (Gillett-Swan, 2017). Student and safety considerations can cause serious problems during online instruction (Phuyal, 2020). Additionally, Students from modest, low-income families often lack access to personal computers and reliable Internet services, and cannot take online courses. (Ghimire, 2020; Ojha, 2020). Many academics felt that the decision to move immediately to online or virtual classrooms was inappropriate given their limited technology and preparation.

A recent ABC News review found that some students do not equate online courses with classroom experiences. (Binkley, 2020). Educators, employers and stakeholders also are debating the usefulness of online learning. Despite the reality that each one educators have issues approximately the feasibility of on line training in Indonesia, they unexpectedly found that students faced four basic problems or challenges regarding online education. I am reporting that I am facing they find it difficult to adapt to technology at first, students often have trouble posting assignments and registering for classes. Second, some students think online classes are not interactive. For example, one student said, "There is a lot of discussion with the teacher and little cooperation." Third, poor network connectivity in many parts of Indonesia make it difficult for students to attend

class and do homework. Fourth, not having access to a computer presents the difficulty of online learning.

#### **4. The Difficulties on Online Learning in Speaking Skill**

There are many problems/difficulties faced by students in learning English, such as difficulty speaking in a foreign language, especially in learning English in terms of speaking skills. In this case, the researcher focused on the difficulties in online learning of speaking skills of students at Universitas Muhammadiyah for the 2021/2022 academic year. As speaking is considered a difficult skill it causes some problems. There are five components to speech difficulty according to Harris (1974): comprehension, grammar, vocabulary, pronunciation and fluency.

##### **4.1. Comprehension**

In oral communication, it definitely needs the subject to respond, to talk and to initiate it. Comprehension is an understanding of the idea. It means people can respond or convey the sentence correctly, it indicates that they comprehend or understand the context well. If two words differ in meaning, students are likely to misinterpret them. Phrases with multiplex interpretations can also be problematic for students. Uncertainty as to the connotations of such phrases can also create difficulties.

##### **4. 2. Grammar**

Grammar is part of learning the correct form (or structure) of a language. The grammar only deals with sentence-level parsing. Similarly, grammar is the definition of the laws that govern the sentences of a language. Students must make correct sentences in conversation. The goal of grammar seems to be knowing the correct way to acquire oral and written language skills. Grammar is very important in learning speaking skills because students should not neglect the importance of language without learning grammar. As a result, many students are afraid to speak English because they feel that their grammar is not perfect.

#### 4.3. Vocabulary

Vocabulary is the words necessary for conversation. Without proper vocabulary, personal thoughts cannot be easily communicated or articulated verbally or in writing. Lack of vocabulary is every other impediment that forestalls newcomers from studying a overseas language. This manner that a confined vocabulary is one of the problems college students face in studying a 2d language. Therefore, students must continue to learn language skills to clarify dialogue.

#### 4.4. Pronunciation

Pronunciation is how students express themselves more clearly when speaking. Phonology refers to the part of grammar that consists of the components and concepts that determine how sounds and patterns differ in language. There are two ways to pronounce them. Phonetic and segmental or linguistic features such as: tone and stress. When students speak, read, or listen to English words, they often

have problems with pronunciation. You still miss pronunciation and how to pronounce it. This is especially noticeable in speaking lessons, teaching and learning processes. English words are difficult for students to pronounce. My concern was that many students' pronunciation was influenced by their mother tongue.

#### 4.5. Fluency

Fluency is the ability to read, speak, or write quickly, fluently, or expressively. However, speakers were able to interpret, respond, and understand easily and concisely in a language that reflected linguistic structure. Fluency can be described as the ability to speak fluently and accurately. When it comes to speaking, the goal of many language learners is to become fluent. Fluid symbols produce coherent, fast moving speech with best a minimum desire of forestall and "hmm" or "crazy." These symptoms and symptoms suggest that the speaker isn't spending a whole lot time searching out the speech factors had to carry meaning.

### **5. Social Media**

Social media is best defined in the context of the previous industrial media paradigm. Traditional media such as television, newspapers, radio, and magazines are one-way, static delivery technologies in which magazines deliver expensive content to consumers, and advertisers insert ads into that content and pay. does not have privileges. Plus, if readers disagree with something, there's no way to give immediate feedback. New web technologies have made it easier for anyone to create and, most importantly, distribute content.

Social media is social interplay among humans sharing or replacing statistics and thoughts in digital groups or networks. Social media has turned out to be a phenomenon in our lives due to the fact all of us makes use of it. Social media is used everywhere. Anyone can join their social media now no longer simplest to computer systems and laptops, however additionally to smartphones. Social media are media commonly used by linguists to communicate on the Internet. Social media is best understood as a new kind of online media group.

Social media is a set of internet-based applications built on ideologies and technologies that enable the creation and sharing of user-generated content and is the underlying platform for social media, including WhatsApp. A social network is a website that allows anyone to create a personal girlfriend website, connect with friends, share information and communicate. While traditional media use print and broadcast media, social media use the internet. Social media invites all parties to participate, contribute openly to provide feedback, comment, and share information without limits. Social networks use WhatsApp, Line, and email to let people have their say in online conversations about anything. These websites allow you to create a personal girlfriend web page and connect with friends to share content and communications.

The power of social media lies in connecting and sharing information with everyone in the world, or with many people at once. He has over 3 billion social media users worldwide. Social media is his web-based platform that is constantly changing and evolving. Social media users tend to be younger, according to the Pew Research Center. Nearly 90% of people between the ages of 18 and he 29 use

at least some form of social media. Social media can take the form of a variety of technology-enabled activities.

## **6. WhatsApp**

One of the most familiar and highly popular communication media to our ears, WhatsApp is the platform we use today for our personal and social gain. This application belongs to almost every gadget user. In addition to long-distance communication, the platform can also be used as a support medium in learning processes such as the current pandemic. This platform is a tool for long-distance communication in the form of conversations using text, images, voice and video. WhatsApp can connect you with your friends and family anytime, anywhere, as long as you have a great network to help you access it. (Habibah et al., 2020). As with the opinion expressed by (Yensy, 2020) that learning with WhatsApp media is quite effective "In accordance with the opinion expressed by (Munawaroh, 2019) that learning with WhatsApp media encourages students to be more active in searching for information and trying to answer questions that are asked, especially when solving exercises. Furthermore, (Ricu Sidiq 2019) also stated the same thing that WhatsApp Group media can be used".

In the learning process, the use of materials can contribute to learning success. According to AECT (Association of Education and Communication Technology), "Media is any form used in the process of disseminating information." Meanwhile, according to (Adam & T.S, 2015) that Learning media are the physical and technical elements of the learning process that help teachers

deliver learning content to students and facilitate the achievement of formulated learning goals. Explain the important role that learning media play in supporting the quality of the teaching and learning process. Media can also make learning more interesting and enjoyable. One of the learning media that is currently developing is audiovisual media. (Irawan & Ermawaty, 2020).

From this, we can conclude that learning media are thought-provoking tools in the teaching and learning process, emotions, attention, abilities or skills of the learner therefore the learning process can be facilitated. Types of Learning Mediums The very rapid development of educational systems affects both the development of learning psychology and the existing education system. This situation encourages and leads to further development of learning technology and new additions to learning media. Learning media are developing rapidly as technology advances, and each existing media has its own characteristics and functions.

## **B. Conceptual Framework**

This study focuses on the cognitive difficulties faced by second-year English education students with online English language Learning during the Covid-19 Pandemic. Online learning is conducted electronically through computer-based media and the Internet. In the midst of the Covid-19 pandemic, this time in the education world, students have made more use of the online learning system provided by the government, allowing teachers and students to study easily anytime, anywhere, free from space, time and flexible places.



The conceptual framework of this research is designed as shown in the figure below:

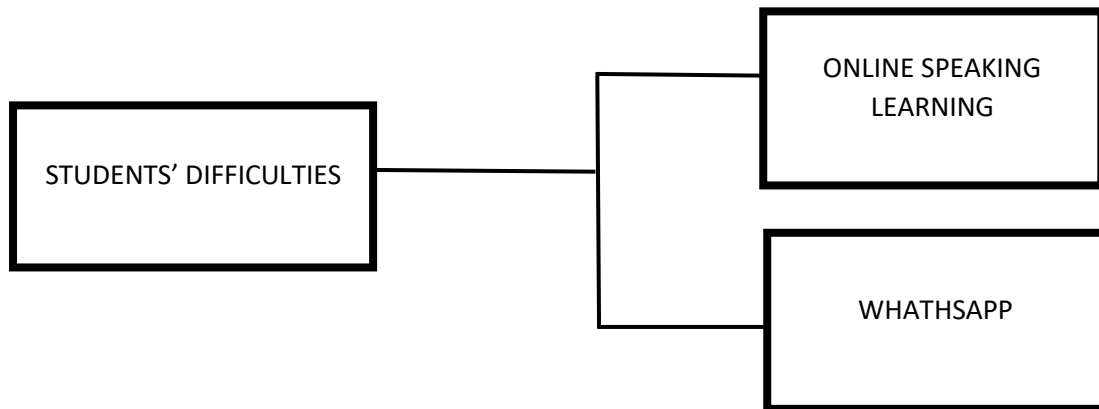

Figure 1 Diagram of Conceptual Framework

### C. Previous Relevant Study

1. Muhamad Riduan, 2021. *The Students' Perceptions of Online Learning During the Covid-19 Pandemic*. Thesis, Department of Language Education, Faculty of Teacher Training and Education, State Islamic Institute of Palangka Raya. Advisors: (I) Rahmadi Nirwanto, M.Pd., (II) Akhmad Ali Mirza, M.Pd.

This research arose from online learning conducted by the government during the Covid-19 pandemic. The 2020/2021 academic year is an online learning experience during his Covid-19 pandemic experienced by a student in the 3rd semester of the IAIN Palangkaraya English Language Teaching and Learning Program. During the Covid-19 pandemic, students did not come to campus to study and only stayed home to participate in online learning.

The purpose of this study was to (1) determine how students in the 3rd semester of the 2020/2021 IAIN Palangkaraya English Language Teaching Study Program

perceive their participation in online learning during the Covid-19 pandemic; to find out. The research is descriptively qualitative, and all data obtained through questionnaires, interviews, and documentation are analyzed descriptively after being categorized into aspects relevant to the questionnaire. The subjects of this study were students in the 3rd semester of her IAIN Palangkaraya's English Language Education and Research Program for the 2020/2021 academic year. Researchers obtained samples using random sampling.

The results of this study indicate that most (1) students perceive positively their participation in online learning during the Covid-19 pandemic. Students can easily access online learning anytime, anywhere. Additionally, some students have a negative perception of participating in online learning during the Covid-19 pandemic due to network issues and lack of class interaction.

2. Tubagus Zam Zam Al Arif, Universitas Jambi, Jl. Lintas Sumatera Jl. Jambi - Muara Bulian No.Km. 15, Mendalo Darat, Kec. Jambi Luar Kota, Kabupaten Muaro Jambi, Jambi 36122, Indonesia, Received: 9th September 2019 Revised: 23rd November 2019 Published: 30th November 2019

This study aims to investigate the use of social media in learning English by English major students at Jambi University. This study used exploratory research to examine the use of social media for learning English. Researchers collected data using surveys and semi-structured interviews. Sixty-seven students responded to the questionnaire, and 10 of her participants were interviewed at random from those who responded to the questionnaire. Quantitative data from

questionnaires were analyzed using baseline statistical analysis and data from interviews were analyzed using a combination of phenomenological case analysis and thematic coding. As a result, we found that students mainly use various social media, such as Instagram and Facebook. As a result, students spent more time using social media for general purposes than studying English. However, they actively used social media while learning English. Students recognize that social media plays an important role in improving their English proficiency. Additionally, we encourage the use of use social media and encourage our students to use social media to improve their English. Also, Instagram is a social media mainly used by Jambi University English Department undergraduates to learn English, and they usually use social media to learn English at home.

3. Harisa Mardiana, Faculty Technology and Science, Universitas Buddhi Dharma, Tangerang, Indonesia, *harisa.mardiana@buddhidharma.ac.id*

People use the internet in the same way today, and surprisingly, students spend more time on social media sites. College students and educators alike believe in social media sites. They found what they needed for education. For example, Facebook is an educational resource with links to other sources. I observed the impact of social media on the educational process and learned about the various positive and negative aspects. The results of this work showed that there were no differences between students and teachers in their evaluation of social media and the Internet among the students and teachers surveyed. A survey has been created and is now available. We propose that there are ways for college courses to use

social media to disseminate content and engage students and educators in ways not previously possible.

The difference between my research and the relevant study is in the use of social media that I use, namely WhatsApp, in my relevance, the use of social media Facebook and Instagram.

## **CHAPTER III**

### **METHOD OF RESEARCH**

#### **A. Research Design**

This chapter is an explanation all the factors related to the method of qualitative research methods. The research was analyze the difficulties students have with online speaking learning, methods of data collection, types of data collected, and technique of analyzing the data.

#### **B. Location of the Study**

This research was conducted by the Faculty of Teacher Training and Education, 7th Semester, English Language Teaching Program, Universitas Muhammadiyah Sumatera Utara.

#### **C. Sources of Data**

The sources of data in this study transcriptions which are relevant with the research in English language students' speaking learning through WhatsApp during their learning process. Other sources of data was students' of English Education Program at VII semester which consist of three parallel classes namely VII A, VII B, and VII C. From the three parallel classes, VII.C was selected as some of data which consist of 15 students.

#### **D. Technique of Collecting Data**

Data were collected using conversational interviews with detailed objectives 6 students were interviewed, there was a feeling interview for feeling, learning strategies and the impact of the online learning process via WhatsApp on their learning.

Collect questions analyze questions select questions and conduct interviews

#### **E. Technique of Data Analysis**

Sugiyono (2016) explain that there are four steps in analyzing data in qualitative research: they are data reduction, data display and conclusion drawing.

##### **1. Data Reduction**

First step was data reduction. Data reduction is a process of choice, Focusing, simplifying, abstracting, and remodeling the statistics that seem in written up subject notes or transcription. The research reduction of students' interview to simplify and categorize the data.

##### **2. Data Display**

After data reduction the next step in data analysis is Data Display. Data display compressed assembly of information that permits conclusion drawing and action. With collecting information, interviews, questionnaires and taking notes on the difficulty of online learning.

### 3. Conclusion Drawing/ Verification

The final activity of qualitative analysis is to draw conclusions from the data collection to drawing conclusions and reviewing data to organize them well.

## CHAPTER IV

### DATA AND DATA ANALYSIS

#### A. Data

In this chapter, the data were collected from interview six respondents consisted of one male students and five female students namely : Muhammad syafii, Syahputri, Denisy Triandini, Nasya Azaraini, Anisa Adetia, Fadilah khusnah. The students of Universitas Muhammadiyah Sumatera Utara in 7<sup>th</sup> semester of English Education Grade C is 15 students. They are divided into classes for the seven semester.

Then based on the students in the 7th semester, the researcher chosen Class C as the respondents because most of them were willing to become respondents, the question I gave them was advantages and disadvantages of online learning, Problems or limitations of studying online, what do you think about online learning, barriers to learning speaking skills and problems using WhatsApp. So there were six students who were ready as the respondents in this research. They were in seven semester who have studied about learning speaking especially during the online learning as the respondents. The study was focused on the difficulties that they faced during online speaking learning process assisted by WhatsApp application.



**Table of Students' interviewed**

<b>No</b>	<b>Name</b>	<b>Class</b>	<b>Gender</b>
1.	MS	VII C	Male
2.	SP	VII C	Female
3.	DT	VII C	Female
4.	NA	VII C	Female
5.	AA	VII C	Female
6.	FH	VII C	Female

**B. Data Analysis**

After interviewing all respondents, the researcher drawn main themes based on their answers. The detail of themes analyzed was as the following:

**1. Difficulties of online speaking learning through WhatsApp**

Five out of six students interviewed said that online speaking learning was difficult due to a lack of vocabulary and being embarrassed to speak for fear of being wrong. They claimed to have a limited vocabulary. Changes in verb forms also contribute to students' lack of ability to speak. AA says that:

"That's difficult. When in online learning, the lecturer uses vocabulary that I rarely understand so it is difficult for me to understand his speech. Sometimes in online learning the lecturer speaks so fast and doesn't sound clear so it's hard to understand.

Then I sometimes don't catch what he's saying because there are some words doesn't sound familiar in my ears.”

Other students such DT said, “The difficulty of speaking to listen is about the accent of native speakers, the high level of vocabulary that has the same distinction but is used so often.”

Difficulties for SP is limited of vocabulary section, for MS There is a limited vocabulary as well. As for DT, there are many difficulties when learning to speak through this online learning. Especially in the vocabulary section where new words appear. The difficulty for NA is the native speaker's accent and high-level vocabulary. And the difficulty of AA is the teacher's speaking speed and noise during online classes. However, the way to increase the vocabulary is to post-it notes that we want to know the vocabulary, study vocabulary near you, read the English article, watch movies, listen to English music and the most effective way is to add every day, two words a day, word which we don't know, don't let go, we have to know immediately. After many days, we will get more and more vocabulary.

For SP and MS learning speaking through online learning is hard because she didn't understand about the meaning of the conversations. “I think learning speaking through online learning is difficult because the limited vocabulary that I have there are still many that I don't know makes it is difficult for me to understand the meaning of the conversation and the limited time required makes it difficult for me to listen.”

NA, and DT added, "There are several difficulties when learning to speak through this online learning, especially in the vocabulary section where many new words appear which must be recorded and then searched for meaning these difficulties take a lot of time, so sometimes many utterances are not heard. So I find it difficult because sometimes I can't get clear speech articulation and lack of vocabulary and limited time." So that they lack understanding or articulation of vocabulary in speech and limited time in listening or listening through online learning during this pandemic, which can make learning difficult.

Almost same like NA and others students, SP said that, "the difficulty on learning speaking is about the accent of native speaker, high level of vocabulary that has same different but so often to use, and the speed of the speaking material, limited time for assignment speaking task."

And AA said, "it is very difficult because various sounds in the environment interfere with the ability of the source of hearing, and the number of vocabularies that are not understood when learning online speaking is due to the speed of the instructor's speaking tone."

Besides that, FH said that learning speaking through online learning is easy. In her opinion, speaking through online learning became not difficult for her because the differences between offline and online learning only the place speaking process happened.

“I think learning speaking in online learning process it is not difficult. Because the differences between offline and online learning are only the place speaking process happened. In online I learn speaking through audios or videos are given by my teacher at home using my mobile phone. But in offline learning process happened in language laboratory.”

There are some difficulties that appear while the students were learning Speaking through online learning, they are:

a. Packaging of the materials

Based on experiences, five out of six students answered interviews that lecturers only provide material via E-Learning or WhatsApp. After that, they didn't explain the material clearly, sometimes I also didn't understand the material provided. As DT said that:

"My lecturer said that the lectures during the pandemic were not good enough. He just gave us material without explaining the lesson. I know maybe this is quite easy to understand but I also need an explanation of the learning. As a teacher they give explanations by zooming in but sometimes their words are hard to understand and hear because their voices are too low or disconnected because of the network."

Then student FH explained that, “The learning speaking my lectures gave during the pandemic weren't that great. He just gave us the material and

didn't explain the text. I know this may be easy to understand, but as a teacher they should explain or zoom in at least twice a week. Then he did the exercises for us. He never zoomed in with students, so I never knew his accent because we were always listening to the audio.” In this section, his lecturer only gave the materials but not explain the materials clearly although the explanation is very important in delivering or learning process especially in this learning situation. And then the lecturer gave them some assignments and still not use Zoom Application.

Other students, AA and DT said, “My lecturer is delivering learning speaking through E-learning. And sometimes through the WA group because if the audio can't be downloaded then the lecturer will send it to the WA group and because the connection is bad. But more often use E-learning.” In this opinion, AA and DT almost told the same opinion that they said their lecturer gave them the materials during online learning process by using WhatsApp Application, then their lecturer made a group to share their listening materials or the audio in there. Because when their lecturer gave them the materials through E-Learning, sometimes they got some obstacles like bad connection, many people access the application or others so it can make them difficult to downloaded the materials.

Students with initial FH added that,” The way how my lecture gives the material is not quite well. He only gives the material and asks the students to answer the following questions without explaining anything. Sometimes it's just a link to be used for listening and sometimes the

delivery of the material delivered in learning.” So, the point of their statements that they didn’t get the learning during this pandemic through zoom and more information about their learning speaking like usual in the offline situations. They only got the materials based on the link after that some questions that relate about the course by using E-Learning or WhatsApp Application.”

Almost same like other students MF told that her lecturer gave them learning speaking through some application like E-Learning but she only gave them assignments in it, but she did not explain the material clearly, “By using E-Learning and give some assignments based on the listening audio that given.”

While SP explained that her lecturer in delivering their course during online learning. She used Zoom Application. She asked her students to join the Application and explain the course by via Zoom, so she didn’t only give the point of materials but she explained it well. But the durations of their Zoom are not long, because of the limited time of their meeting and the application,” My lecturer delivering online speaking learning or material is nice and more powerful because we have a short time in via zoom but we need long time.”

NA added, “Usually, the lecturers who enter provide material from videos made by themselves, but not infrequently also provide learning video links that can be watched on YouTube according to the learning material.” So, it can make the students little bit understand about the

material cause the lecturer have been made the explanation by using a video record and they tried to give them more examples about the speaking learning by giving them a link of YouTube Application that related about their materials.

### **C. Research Findings**

The main purpose of this research was to clarify the difficulties faced by students in online speaking learning process assisted by WhatsApp application. After analyzing the interview results, the findings can be presented as mentioned below.

1. Five of six interviewed students told that speaking learning through online learning have some difficulties. According to them, the difficulties that the students faced little bit make them hard to get the materials of speaking learning clearly and well. The difficulties of the speaking during online learning in this pandemic are due to a lack of vocabulary and being embarrassed to speak for fear of being wrong. They claimed to have a limited vocabulary. Changes in verb forms also contribute to students' lack of ability to speak. Some students said when on online learning, the lecturer uses vocabulary that I rarely understand so it is difficult for me to understand his speech. Sometimes in online learning the lecturer speaks so fast, doesn't sound clear and accent of native speakers so it's hard to understand. Some student she didn't understand about the meaning of the conversations especially in the vocabulary section where many new words appear

which must be recorded and then searched for meaning, these difficulties take a lot of time, so sometimes many utterances are not heard. So I find it difficult because sometimes I can't get clear speech articulation and lack of vocabulary and limited time. But there is a student that said the online speaking learning it is not hard. Because the differences between online and offline class are only about the place of the listening process happened. In online learning, the students got the materials through audio and video which lecturer shared from link or others application that support the online learning. While in offline learning process, the students got the materials in language laboratory.

2. When the students' difficulties of online speaking learning process, they tried to prepare that everything relate about listening course such as listen to a podcasts or native speakers' video, until listen music in YouTube Application. It could make them easier to get the point of listening and practice their speaking skill. But sometimes they also only took a note and wrote the difficult words in the materials. After that, they found out the words in Google Application or online dictionary for more details and asked to their friends who have understood about the materials.



## CHAPTER V

### CONCLUSION AND SUGGESTION

#### A. Conclusion

After analyzing the data, the researcher concluded that the difficulty of online language learning via WhatsApp was the biggest problem due to lack of vocabulary and pronunciation. English proficiency depends on the vocabulary knowledge of second and foreign language learners, as well as native speakers. Vocabulary development is essential, but it poses some problems, especially for non-native English speakers. Students with low vocabulary demonstrate poor academic performance in a variety of courses related to college-level language proficiency, linguistics, literature, and translation. And also, factors that cause problems with pronunciation and speaking include lack of general knowledge, lack of practice in speaking, fear of making mistakes, lack of practice in word usage and grammar, low motivation, and low engagement. Laziness in reading, shyness, poor use of dictionaries, nervousness, fear of criticism or pronunciation of unfamiliar words.

However, all the difficulties can be solved. Language learners need to expand their vocabulary and develop their language repertoire by expanding their vocabulary. However, learning vocabulary can be difficult, especially for non-native English speakers who have trouble with the meaning, spelling,

pronunciation, correct use of words, and inferring meaning from context of new words.

### **B. Suggestion**

Based on the conclusion, below are some suggestions from this research.

For the lecturer should be enlarge their teaching method about how to increase the way to learning process especially in learning speaking during the pandemic with all the difficulties. For the students who are studying online speaking learning process, they have to increase their ability in listening skill from many applications which support the speaking skill and should be got more information about the materials clearly and well.

## REFERENCES

- Adam, S., & T.S, M. (2015). *Pemanfaatan Media Pembelajaran Berbasis Teknologi Informasi Bagi Siswa Kelas X SMA Ananda Batam*. CBIS Journal, 3(2), 78–90.
- Binkley, C. (2020, May 5). Unimpressed by online classes, college students seek refunds. abc News, Retrieved <https://abcnews.go.com>
- Burns, A. (1998). Teaching speaking. *Annual Review of Applied Linguistics*, 18, 102-123.
- Bjork. (2011). *Desirable difficulties in theory and practice*. Journal of Applied research in Memory and Cognition, 9 (4), 475-479.
- Chaney, A. L. (1998). *Teaching Oral Communication*. Boston: Allyn and Bacon.
- Cojocariu, V.-M., Lazar, I., Nedeff, V., & Lazar, G. (2014). *SWOT analysis of e-learning educational services from the perspective of their beneficiaries*. Procedia-Social and Behavioral Sciences.
- Costley, K. C. (2014). *The positive effect of technology on teaching and student learning*. Arkansas Tech University.
- Fry, K. (2001). *E-learning markets and providers: some issues and prospects*. Education Training, 233-239.
- Gillett-Swan, J. (2017). The challenges of online learning: Supporting and engaging the isolated learner. *Journal of Learning Design*, 10(1), 20-30
- Ghimire, B. (2020, May 28). *Digital divide too wide for online classes to succeed in Nepal*. The Kathmandu Post, Retrieved <https://kathmandupost.com>
- Habibah, R., Salsabila, U. H., Lestari, W. M., Andaresta, O., & Yulianingsih, D. (2020). *Pemanfaatan Teknologi Media Pembelajaran di Masa Pandemi Covid-19*. Trapsila: Jurnal Pendidikan Dasar, 2(02).
- Haris, David P.(1974). *Testing English as A second Language*, New York .Mc. Graw Hill Book Company.
- Hounsell, A. a. (2007). *Difficulties and Strategies in Learning English: An Analysis of Students From English and Non-English*. Advances in Social Science, Education and Humanities.

- Huang, (2002). Understanding Difficulties and Resulting Confusion in Learning. *Melbourne Centre for the Study of Higher Education, University of Melbourne, Melbourne, VIC, Australia, 2School of Education, University of Queensland, St Lucia, QLD, Australia, 3University of Technology Sydney, Sydney, NSW, Australia, 4Department of Educat.*
- Irawan, V., & Ermawaty, I. R. (2020). Analisis\_kebutuhan\_media\_pembelajaran. PROSIDING Seminar Nasional Pendidikan Fisika FITK UNSIQ 2020, 2(1), 1–6.
- John, S. (2020, May 19). 'What is Google Meet?': A guide to Google's video-chatting service, including pricing options and how to join a meeting. Retrieved from Business Insider: <https://www.businessinsider.com/what-is-google-meet?r=US&IR=T>.
- Liu, Y., & Wang, H. (2009). A comparative study on e-learning technologies and products: from the East to the West. *Systems Research & Behavioral Science*, 26(2), 191–209.
- Maltz, L., Deblois, P. & The Educause Current Issues Committee (2005). Top Ten It Issues. *Educause Review*, 40(1), 15-28.
- Munawaroh, I. (2019). *Penggunaan Media Sosial Sebagai Upaya Meningkatkan Hasil Belajar Matematika Peserta Didik Kelas IX di SMP Negeri 1 Sindangkasih*. Prosiding Seminar Nasional & Call For Papers, 1(9), 266–273.
- Naidu. (2006) *E-Learning A Guidebook of Principles, Procedures and Practices*. In E-learning.
- Phuyal, K. (2020, April 10). Challenges of Virtual Class. *Himalayan Times*, Retrieved
- Richard, H., & Haya, A. (2009). Examining student decision to adopt web 2.0 technologies: theory and empirical tests. *Journal of computing in higher education*, 21(3), 183-198.
- Sidiq, R. (2019). Pemanfaatan Whatsapp Group dalam Pengimplementasian Nilai-Nilai Karakter Pancasila Pada Era Disrupsi. Puteri Hijau: *Jurnal Pendidikan Sejarah*, 4(2), 145-154.
- Subedi, A. (2020, May 10). Guru karma in virtual times. *The Kathmandu Post*, Retrieved <https://kathmandupost.com>, *Journal Of English Language teaching, Vol 5 No.1 Tahun 2021*.

- Wentling T.L, Waight C, Gallagher J, La Fleur J, Wang C, Kanfer A. (2000). E-learning -a review of literature. Knowledge and Learning Systems Group NCSA9.1–73.
- Woolf, B. W. (1980). Webster's New Colligate Dictionary English students perception on the use of WhatsApp group in speaking class. *Journal education edutama*.
- Wulandari, Rian. Improving students' speaking ability through communicative language games at SMPN 1 Prambanan grade VII A in the academic year of 2013 / 2014. Universitas Negeri Yogyakarta: Yogyakarta.
- Yanto. (2015). *Belajar Bahasa Inggris Melalui Media*. Kompasiana: <http://www.kompasiana.com/yantomed/belajar-bahasa-Inggris-melaluimedia>.
- Yensy, N. A. (2020). Efektifitas Pembelajaran Statistika Matematika melalui Media Whatsapp Group Ditinjau dari Hasil Belajar Mahasiswa (Masa Pandemi Covid 19). *Jurnal Pendidikan Matematika Raflesia*, 05(02), 65–74. <https://ejournal.unib.ac.id/index.php/jpmr>.

## **APPENDIX**

### Interview Questions

1. How do you feel about learning speaking via WhatsApp?
2. Advantages of studying online through WhatsApp?
3. Problems or limitations related in online learning process?
4. Disadvantages of studying online through WhatsApp?
5. What are your concerns in online learning process?
6. What are your thoughts on online speaking learning via WhatsApp during the covid-19 pandemic?
7. What are the biggest obstacles to students' learning in speaking skill?
8. Whether students have problems using WhatsApp in learning speaking skill?
9. Between studying online and studying in the classroom, which do you prefer? And why?
10. Whether students have a shortage of equipment to study online?

## INTERVIEW

Day/Date : Friday / Sep 16th 2022

Time : 10.00 – 12.00 wib

Setting /Location : Classroom/ VII C

Name (Responder) : MS

1. Researcher : How do you feel about learning speaking via WhatsApp?

Students: I feel frightened. Personally, I'm someone likes a normal classroom atmosphere.

2. Researcher : Advantages of studying through WhatsApp?

Students: Study online can study anywhere and have convenient to study, without wasting time traveling.

3. Researcher : Problems or limitations related in online learning process?

Students: Personally, I don't have a problem with studying online, this is convenient, but there are some distractions that require more meditation than in the classroom.

4. Researcher : Disadvantages of studying through WhatsApp?

Students: There is no motivation to study.

5. Researcher : What are you concerns in online learning process during the covid-19 pandemic?

Students: I have a lot of concerns with online exams as there are technical issues that can arise at any time such as internet down or the answer sheet may have been sent, but it did not arrive.

6. Researcher : What are you thoughts on online speaking learning via WA?



Students: I think studying via WA It is an app that is easy to access and convenient to study.

7. Researcher : What are the biggest obstacles to students' learning in speaking skill ?

Students: Poor English foundation, not remembering basic words, causing obstacles in speaking English.

8. Researcher : Whether studen's have problems using WhatApp in learning speaking skill?

Students: No problems

9. Researcher : Between studying online and studying in the classroom which do you prefer? And why?

Students: I like studying in the classroom because it is a face-to-face teaching that will concentrate more on studying because the teacher is in front. And can also talk to classmates, practice English interactions with classmates.

10. Researcher : Wheter students have a shortage of equipment to study online? Students: There is no problem with learning materials.

## INTERVIEW

Day/Date : Saturday / Sep 17th 2022

Time : 10.00 – 12.00 wib

Setting /Location : Classroom/ VII C

Name (Responder) : SP

1. Researcher : How do you feel about learning speaking via WhatsApp?

Students: I see that studying online has both pros and cons, advantages of saving time and traveling to college but on the downside, some days there may be quite long technical glitches.

2. Researcher : Advantages of studying online through WhatsApp?

Students: Practice using technology, practice using various programs or applications in online learning.

3. Researcher : Problems or limitations related in online learning process?

Students: If discussing the problem is often a technical problem, especially the internet, regardless of the source or their own because we can't know when the signal will stabilize, so this is very disturbing and then causing us to miss some content that is in the range of the internet problem.

4. Researcher : Disadvantages of studying through WhatsApp?

Students: Internet signals sometimes the internet may not be good, causing the voice of the instructor to speak, may not be clear or stumbling.

5. Researcher : What are your concerns in online learning process during the covid-19 pandemic?

Students: There are some concerns in the internet. But will be worried during the exam if delivered at the specified time point will be lost.

6. Researcher : What are your thoughts on online speaking learning via WA?

Students: Voice recordings of teachers' speeches can be listened to later in WA group chats.

7. Researcher : What are the biggest obstacles to students' learning in speaking skill ?

Students: dare not speak, dare not show, afraid of making fun of friends while speaking, This is a huge obstacle for me.

8. Researcher : Whether students have problems using WhatsApp in learning speaking skill?

Students: In terms of instant interaction in zoom, sometimes you can't think of words, get excited.

9. Researcher : Between studying online and studying in the classroom, Which do you prefer? And why?

Students: Like to study in the classroom more than studying online because Study in the classroom have fun and can meet friends. If you don't understand, can ask friends at that time.

10. Researcher : Whether students have a shortage of equipment to study online?

Students: There is a problem in online classes. I have a telephone low spec sometime maybe unable to join the class.

## INTERVIEW

Day/Date : Monday / Sep 19th 2022

Time : 10.00 – 12.00 wib

Setting /Location : Classroom/ VII C

Name (Responder) : DT

1. Researcher : How do you feel about learning speaking via WhatsApp?

Students: I feel that it is something new to study online. I don't think that once in a student's life, they have studied in a system like this from when we were studying with many friends but having to sit alone to study makes learning less fun.

2. Researcher : Advantages of studying online through WhatsApp?

Students: The advantage is that if you don't understand, you can click back and look to review the content.

3. Researcher : Problems or limitations related in online learning process?

Students: The problem or limitation of online learning is Think that it at the atmosphere at home, not very conducive to studying because at home is a shop, sometimes at home I don't know that we are currently studying and will call to sell some things, call to work.

4. Researcher : Disadvantages of studying through WhatsApp?

Students: The disadvantage is that there is no concentration in studying, the place is not conducive to noise.

5. Researcher : What are your concerns in the online learning process during the covid-19 pandemic?

Students: For me, in terms of studying, I'm not quite concerned.

6. Researcher : What are your thoughts on online speaking learning via WA?

Students: Learning to speak via WhatsApp is another convenient way, just click on the Zoom link to join the class.

7. Researcher : What are the biggest obstacles to students' learning in speaking skill ?

Students: There is no opportunity to actually use it, and in the society around us, no one speaks English, so it is difficult to practice.

8. Researcher : Whether students have problems using WhatsApp in learning speaking skill?

Students: If talking about the problem of using WhatsApp to learn, for me there is no problem.

9. Researcher : Between studying online and studying in the classroom, which do you prefer? And why?

Students: Personally, I like to study in the classroom more because studying in the classroom is more focused and motivated than studying online.

10. Researcher : Whether students have a shortage of equipment to study online? Students: Personally, I have no problem with school supplies.

## INTERVIEW

Day/Date : Tuesday / Sep 20th 2022

Time : 10.00 – 12.00 wib

Setting /Location : Classroom/ VII C

Name (Responder) : NA

1. Researcher : How do you feel about learning speaking via WhatsApp?

Students: I feel that we have learned more conveniently where we can study, which is suitable for the modern world where we can learn anywhere via internet. When it's time to study, we can learn right from home without having to go into the classroom.

2. Researcher : Advantages of studying online through WhatsApp?

Students: Teaching content is modern and always updated.

3. Researcher : Problems or limitations related in online learning process?

Students: Problems with surrounding conditions Because studying online is different from studying in a classroom, especially with the feeling that we have to pay attention to study, When it's an online system, it takes some concentration to study.

4. Researcher : Disadvantages of studying through WhatsApp?

Students: Teacher and student relationship is distant.

5. Researcher : What are your concerns in online learning process during the covid-19 pandemic?

Students: As for concerns about private studies, there are none.

6. Researcher : What are your thoughts on online speaking learning via WA?

Students: Learning to speak online makes us practice discipline difficult to practice speaking by ourselves, besides, the surrounding society does not speak English.

7. Researcher : What are the biggest obstacles to students' learning in speaking skill ?

Students: They are worried that they will not speak correctly according to the language, they are worried about the grammar that they are speaking or they are afraid that the accent will not be like a native speaker and people will laugh at it.

8. Researcher : Whether students have problems using WhatsApp in learning speaking skill?

Students: There is no problem using WhatsApp. There will be a problem with listening to the voice sent by the teacher in the chat group because my phone has a problem listening to the voice in the chat.

9. Researcher : Between studying online and studying in the classroom, Which do you prefer? And why?

Students: Prefer to study online more than studying in the classroom because online classes do not have to travel, save costs and do not have to travel to be tired.

10. Researcher : Whether students have a shortage of equipment to study online?

Students: I will have a problem with my phone sometimes not being able to listen to the teacher's explanation in the group chat because sometimes the teacher records audion the explanation and sends it through the group chat.



## INTERVIEW

Day/Date : Wednesday / Sep 21th 2022

Time : 10.00 – 12.00 wib

Setting /Location : Classroom/ VII C

Name (Responder) : AA

1. Researcher : How do you feel about learning speaking via WhatsApp?

Students: The transition from classroom learning to online is a very rapid change that affects student adaptation. In the private, thinking about the normal form of teaching in the room is more efficient than online learning because studying in the room will have an environment around the body that encourages us to study fully.

2. Researcher : Advantages of studying online through WhatsApp?

Students: The advantage is that it stimulates yourself and organize self-discipline

3. Researcher : Problems or limitations related in online learning process?

Students: There are quite a few problems in studying online, especially the stability of the internet signal, which may be dropped, jerky or stumbled.

4. Researcher : Disadvantages of studying through WhatsApp?

Students: Unfavorable communication equipment

5. Researcher : What are your concerns in online learning process during the covid-19 pandemic?

Students: There were some concerns about studying in the early stages, but when I adapted, I was quite not worried.

6. Researcher : What are your thoughts on online speaking learning via WA?

Students: Learning online speech is not effective like studying in the classroom because studying in the classroom is like listening to the English speaking voice, making us listen and speak better.

7. Researcher : What are the biggest obstacles to students' learning in speaking skill ?

Students: inability to distinguish sounds of similar words such as "fill" with "feel" causing distorted pronunciation and incomprehensible conversation.

8. Researcher : Whether students have problems using WhatsApp in learning speaking skill?

Students: The problem is that I can't click on the zoom link in WhatsApp because the internet signal is unstable or sometimes I can join Zoom, but the sound is interrupted, causing me to not understand the lesson.

9. Researcher : Between studying online and studying in the classroom, Which do you prefer? And why?

Students: Prefer to study in the classroom because studying in the classroom will concentrate more on studying than studying online.

10. Researcher : Whether students have a shortage of equipment to study online?

Students: The main problem is that the phone memory is full and it is difficult to send work. Converting files or perhaps not being able to save the knowledge sheet.

## INTERVIEW

Day/Date : Thursday/ Sep 22th 2022

Time : 10.00 – 12.00 wib

Setting /Location : Classroom/ VII C

Name (Responder) : FH

1. Researcher : How do you feel about learning speaking via WhatsApp?

Students: Phil in class, it's different, it makes me feel like I can study or not study at that time just follow the clip May cause pickling of the tape different from studying in class.

2. Researcher : Advantages of studying online through WhatsApp?

Students: Study as well, help with household chores, or look after parents who may be sick at home.

3. Researcher : Problems or limitations related in online learning process?

Students: It may be difficult for people who do not have equipment if using a phone, some people are too small not suitable for viewing, some people have money restrictions about borrowing a laptop.

4. Researcher : Disadvantages of studying through WhatsApp?

Students: access to online learning materials, whether mobile phone Laptop or internet signal is limited.

5. Researcher : What are you concerns in online learning process during the covid-19 pandemic?

Students: For me, I'm not worried about studying, but I'm more worried about exams.

6. Researcher : What are your thoughts on online speaking learning via WA?

Students: Online learning in some sessions may be able to listen to, review, record recordings, sometimes teaching live, unable to look back.

7. Researcher : What are the biggest obstacles to students' learning in speaking skill ?

Students: Lack of confidence, fear of saying the wrong words, unable to think of words when speaking seriously, bad accent, dare not speak.

8. Researcher : Whether students have problems using WhatsApp in learning speaking skill?

Students: There may be a slight problem sometimes, but most of the time it's not a problem.

9. Researcher : Between studying online and studying in the classroom, Which do you prefer? And why?

Students: I like to study online because I can study wherever I am and can also share my time to help my parents or work part-time as well.

10. Researcher : Whether students have a shortage of equipment to study online? Students: For me, there are no equipment issues.

## **CURRICULUM VITAE**

### **IDENTITY**

1. Name : Miss Nadia Niyom
2. Place/Date of Birth : Pathumthani, 16 of January 1999
3. Student's Number : 1802050124
4. Gender : Female
5. Religion : Islam
6. Address : Bangphonuea
7. E-mail : missnadianiyom@gmail.com
8. Department of : English Education

### **EDUCATION**

- 2005 – 2006 Kindergarten School (TK) Suroutmajaroen
- 2006 – 2012 Primary School (SD) Suroutmajaroen
- 2012 – 2015 Junior High School (SMP) Suroutmajaroen
- 2015 – 2018 Senior High School (SMA) Phattana Islam Wittaya
- 2018 – 2022 Bachelor's Degree Strata 1 in English Education  
Department, Faculty of Teacher Training and Education,  
University of Muhammadiyah Sumatera Utara (UMSU)



MAJELIS PENDIDIKAN TINGGI  
UNIVERSITAS MUHAMMADIYAH SUMATERA UTARA  
FAKULTAS KEGURUAN DAN ILMU PENDIDIKAN  
Jl. Kapten Mukhtar Basri No.3 Telp.(061)6619056 Medan 20238  
Website :<http://www.fkip.umsu.ac.id> E-mail: [fkip@umsu.ac.id](mailto:fkip@umsu.ac.id)

**PERMOHONA PERSETUJUAN JUDUL SKRIPSI**

Nama : Miss Nadia Niyom  
NPM : 1802050124  
ProgramStudi : Pendidikan Bahasa Inggris

JUDUL	DITERIMA
Students difficulties in online learning process through social media in english department	<i>AC</i> 17/7/22

Bermohon kepada Dosen Pembimbing untuk mengesahkan Judul yang diajukan kepada Program Studi Pendidikan Bahasa Inggris

Medan, 14 July 2022

Disetujui oleh  
Dosen Pembimbing

*Rini Ekayati, S.Pd*  
(Rini Ekayati, S.Pd)

Hormat Pemohon

*Nadia Niyom*  
(Miss Nadia Niyom)



MAJELIS PENDIDIKAN TINGGI  
 UNIVERSITAS MUHAMMADIYAH SUMATERA UTARA  
 FAKULTAS KEGURUAN DAN ILMU PENDIDIKAN  
 Jl. Kapten Mukhtar Basri No.3 Telp.(061)6619056 Medan 20238  
 Website : <http://www.fkip.umsu.ac.id> E-mail: [fkip@umsu.ac.id](mailto:fkip@umsu.ac.id)

Yth : Bapak/Ibu Ketua & Sekretaris  
 Program Studi Pendidikan Bahasa Inggris  
 FKIP UMSU

Perihal : **PERMOHONAN PERSETUJUAN JUDUL SKRIPSI**

Dengan hormat, yang bertanda tangan di bawah ini :

Nama : Miss Nadia Niyon  
 NPM : 1802050124  
 Program Studi : Pendidikan Bahasa Inggris  
 IPK Kumulatif : 3,32

IPK = 3,32

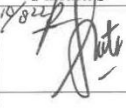
Persetujuan Ketua/Sek Prodi	Judul yang diajukan	Disyahkan Oleh Dekan Fakultas
	Students' difficulties in online learning process through social media in English department	
	The student's awareness of online learning during the covid-19 pandemic	
	The convincingness of online learning on social during covid-19 pandemic	

Demikianlah permohonan ini saya sampaikan untuk dapat pemeriksaan dan persetujuan serta pengesahan, atas kesediaan Bapak/Ibu saya ucapkan terima kasih.

Medan,

Hormat Pemohon,

  
 Miss Nadia Niyon

Dibuat Rangkap 3 :  
 - Untuk Dekan/Fakultas  
 - Untuk Ketua/Sekretaris Prodi  
 - Untuk Mahasiswa yang bersangkutan



MAJELIS PENDIDIKAN TINGGI  
UNIVERSITAS MUHAMMADIYAH SUMATERA UTARA  
FAKULTAS KEGURUAN DAN ILMU PENDIDIKAN  
Jl. Kapten Mukhtar Basri No.3 Telp.(061)6619056 Medan 20238  
Website :<http://www.fkip.umsu.ac.id> E-mail: [fkip@umsu.ac.id](mailto:fkip@umsu.ac.id)

Kepada Yth : Bapak/Ibu Ketua & Sekretaris  
Program Studi Pendidikan Bahasa Inggris  
FKIP UMSU

Assalamu'alaikum Wr. Wb.

Dengan hormat, yang bertanda tangan di bawah ini :

Nama : Miss Nadia Niyom  
NPM : 1802050124  
ProgramStudi : Pendidikan Bahasa Inggris

Mengajukan permohonan persetujuan proyek proposal/risalah/makalah/skripsi sebagai tercantum di bawah ini dengan judul sebagai berikut : Students difficulties in online learning process through social media in English department

Sekaligus saya mengusulkan/menunjuk Bapak/Ibu sebagai :

Dosen Pembimbing : RINI EKAYATI, S,S. MA.

Sebagai Dosen Pembimbing proposal/risalah/makalah/skripsi saya

Demikianlah permohonan ini saya sampaikan untuk dapat pengurusan selanjutnya. Akhirnya atas perhatian dan kesediaan Bapak/Ibu saya ucapkan terima kasih.

Medan,  
Hormat Pemohon,

Miss Nadia Niyom

Dibuat Rangkap 3 :

- Untuk Dekan/Fakultas
- Untuk Ketua/Sekretaris Prodi
- Untuk Mahasiswa yang bersangkutan



**FAKULTAS KEGURUAN DAN ILMU PENDIDIKAN  
UNIVERSITAS MUHAMMADIYAH SUMATERA UTARA  
Jln. Mukhtar Basri BA No. 3 Telp. 6622400 Medan 20217 Form : K3**

Nomor : 1639/II.3/UMSU-02/F/2022  
Lamp : ---  
Hal : **Pengesahan Proyek Proposal  
Dan Dosen Pembimbing**

Bismillahirrahmanirrahim  
Assalamu'alaikum Wr. Wb

Dekan Fakultas Keguruan dan Ilmu Pendidikan Universitas Muhammadiyah Sumatera Utara menetapkan Perpanjangan proposal/risalah/makalah/skripsi dan dosen pembimbing bagi mahasiswa yang tersebut di bawah ini :

Nama : Miss Nadia Niyom  
N P M : 1802050124  
Program Studi : Pendidikan Bahasa Inggris  
Judul Penelitian : **Students' Difficulties in Online Learning Process Through Social Media in English Department.**

Pembimbing : **Rini Ekayati, S.S., MA.**

Dengan demikian mahasiswa tersebut di atas diizinkan menulis proposal/risalah/makalah/skripsi dengan ketentuan sebagai berikut :

4. Penulis berpedoman kepada ketentuan yang telah ditetapkan oleh Dekan
5. Proyek proposal/risalah/makalah/skripsi dinyatakan **BATAL** apabila tidak selesai pada waktu yang telah ditentukan.
6. Masa daluwarsa tanggal : **11 Agustus 2023**

Medan 13 Muharram 1444 H  
11 Agustus 2022 M



Wassalam  
Dekan  
  
**Dra. Hj. Svamsu Lita, MPd.**  
NIDN : 0004066701

- Dibuat rangkap 5 (lima) :
6. Fakultas (Dekan)
  7. Ketua Program Studi
  8. Pembimbing Materi dan Teknis
  9. Pembimbing Riset
  10. Mahasiswa yang bersangkutan :  
**WAJIB MENGIKUTI SEMINAR**





**MAJELIS PENDIDIKAN TINGGI**  
**UNIVERSITAS MUHAMMADIYAH SUMATERA UTARA**  
**FAKULTAS KEGURUAN DAN ILMU PENDIDIKAN**  
Jl. Kapten Mukhtar Basri No. 3 Medan 20238 Telp. 061-6622400 Ext. 22, 23, 30  
Website: <http://www.fkip.umsu.ac.id> E-mail: [fkip@umsu.ac.id](mailto:fkip@umsu.ac.id)



### LEMBAR PENGESAHAN HASIL SEMINAR PROPOSAL

Proposal yang sudah diseminari oleh mahasiswa di bawah ini:

Nama Lengkap : Miss Nadia Niyom  
N.P.M : 1802050124  
Program Studi : Pendidikan Bahasa Inggris  
Judul Proposal : Students' Difficulties in Online Speaking Learning Process Assisted by WhatsApp Application

Pada hari Kamis, tanggal 13, bulan Oktober, tahun 2022 sudah layak menjadi proposal skripsi.

Medan, 13 Oktober 2022

Disetujui oleh:

Dosen Pembimbing

**Rini Ekyati, S.S., M.A.**

Dosen Pembahas

**Rita Harisma, S.Pd., M.Hum.**

Diketahui oleh  
Ketua Program Studi,

**Pirman Ginting, S.Pd., M.Hum.**



MAJELIS PENDIDIKAN TINGGI  
UNIVERSITAS MUHAMMADIYAH SUMATERA UTARA  
FAKULTAS KEGURUAN DAN ILMU PENDIDIKAN  
Jl. Kapten Mukhtar Basri No. 3 Telp. (061) 6619056 Medan 20238  
Website: <http://www.fkip.umsu.ac.id> E-mail: [fkip@umsu.ac.id](mailto:fkip@umsu.ac.id)



### BERITA ACARA BIMBINGAN PROPOSAL

Perguruan Tinggi : Universitas Muhammadiyah Sumatera Utara  
Fakultas : Keguruan dan Ilmu Pendidikan  
Jurusan/Prog. Studi : Pendidikan Bahasa Inggris  
Nama Lengkap : Miss nadia Niyom  
N.P.M : 1802050124  
Program Studi : Pendidikan Bahasa Inggris  
Judul Proposal : Students' Difficulties in Online Learning Process Through Social Media in English Department

Tanggal	Deskripsi Hasil Bimbingan Proposal	Tanda Tangan
2/8/2022	Chapter I, - Background : still not clear about the exact problem related to the topic - Identification : state based on the problem - Significance : not clear	
11/8/2022	Chapter II : revise un-used reference Chapter III : describe the research design clearly Reference : write your reference APA format	
20/8/2022	Chapter I : Revise Chapter III : your source of data need to be more specific.	
25/8/2022	Chapter I and III : Revise as instructed	
14/09/2022	Check all the element in your proposal	
22/09/2022	Final revision	
3/10/2022		

Diketahui oleh:  
Ketua Prodi

(Pirman Ginting, S.Pd., M.Hum.)

Medan, Oktober 2022

Dosen Pembimbing

(Rini Ekayati, SS, MA)



**MAJELIS PENDIDIKAN TINGGI**  
**UNIVERSITAS MUHAMMADIYAH SUMATERA UTARA**  
**FAKULTAS KEGURUAN DAN ILMU PENDIDIKAN**  
Jl. Kapten Mukhtar Basri No. 3 Medan 20238 Telp. 061-6622400 Ext, 22, 23, 30  
Website: <http://www.fkip.umsu.ac.id> E-mail: [fkip@umsu.ac.id](mailto:fkip@umsu.ac.id)

**BERITA ACARA SEMINAR PROPOSAL**

Pada hari ini Kamis Tanggal 13 Bulan Oktober Tahun 2022 diselenggarakan seminar prodi Pendidikan Bahasa Inggris menerangkan bahwa :

Nama Lengkap : Miss Nadia Niyom  
N.P.M : 1802050124  
Program Studi : Pendidikan Bahasa Inggris  
Judul Skripsi : Students' Difficulties in Online Learning Process Through Social Media in English Department

No	Masukan dan Saran
Bab I	Revisi: Judul: batasan pembelajaran bahasa Inggris Revisi Bab 3 batasan judul
Bab II	Revisi: sesuai pertemuan judul
Bab III	Revisi: Location of the Study Sources of Data.
Lainnya	-perjelas format mesin yang dibahas - Referensi: the systematic written of title Book in Reference.
Kesimpulan	[ ] Disetujui [ ] Ditolak [ ] Disetujui Dengan Adanya Perbaikan

Dosen Pembimbing

  
(Rini Ekawati, S.S., M.A.)

Dosen Pembahas

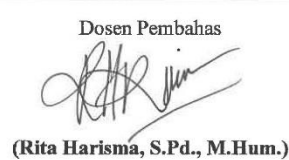
  
(Rita Harisma, S.Pd., M.Hum.)

Panitia Pelaksana

Ketua

  
(Pirman Ginting, S.Pd., M.Hum.)

Sekretaris

  
(Rita Harisma, S.Pd., M.Hum.)



**UMSU**

Unggul | Cerdas | Terpercaya

Bila menjawab surat ini agar disebutkan nomor dan tanggalnya

MAJELIS PENDIDIKAN TINGGI PENELITIAN & PENGEMBANGAN PIMPINAN PUSAT MUHAMMADIYAH  
**UNIVERSITAS MUHAMMADIYAH SUMATERA UTARA**  
**FAKULTAS KEGURUAN DAN ILMU PENDIDIKAN**

UMSU Terakreditasi A Berdasarkan Keputusan Badan Akreditasi Nasional Perguruan Tinggi No. 89/SK/BAN-PT/Akred/PT/III/2019

Pusat Administrasi: Jalan Mukhtar Basri No. 3 Medan 20238 Telp. (061) 6622400 - 66224567 Fax. (061) 6625474 - 6631003

<http://fkip.umsu.ac.id> ✉ [fkip@umsu.ac.id](mailto:fkip@umsu.ac.id) [f](#) [umsumedan](#) [@um:umedan](#) [umsumedan](#) [umsumedan](#)

**SURAT KETERANGAN**

Nomor : 2896/KET/II.3-AU/UMSU-02/F/2022

*Bismillahirrahmanirrahim*  
*Assalamu'alaikum Wr. Wb*

Dekan Fakultas Keguruan dan Ilmu Pendidikan Universitas Muhammadiyah Sumatera Utara menerangkan bahwa :

Nama Mahasiswa : Miss Nadia Niyom  
N P M : 1802050124  
Program Studi : Pendidikan Bahasa Inggris  
Semester : XI ( Sembilan )  
Tahun Akademik : 2022/2023

Adalah benar mahasiswa Fakultas Keguruan dan Ilmu Pendidikan Universitas Muhammadiyah Sumatera Utara, mahasiswa tersebut di atas aktif mengikuti perkuliahan, surat keterangan ini dikeluarkan untuk dipergunakan dalam melaksanakan kewajiban tugas akhir penelitian/riset skripsi di Program Studi Bahasa Inggris, dengan Judul Penelitian " Students' Difficulties in Online Speaking Learning Process Assisted by WhatsApp Application "

Demikian surat keterangan ini dikeluarkan untuk dapat dipergunakan sebagaimana mestinya. Selamat sejahteralah kita semuanya, Amin.

Medan, 13 Rabbilul Akhir 1444 H  
8 Nopember 2022 M

Wassalam

Dekan,  
Wakil Dekan I



**Dr. Hj. Samsuryukita, M.Pd.**  
NIDN: 0004066701



**\*\* Peringatan \*\***



**MAJELIS PENDIDIKAN TINGGI**  
**UNIVERSITAS MUHAMMADIYAH SUMATERA UTARA**  
**FAKULTAS KEGURUAN DAN ILMU PENDIDIKAN**  
Jl. Kapten Mukhtar Basri No. 3 Telp. (061) 6619056 Medan 20238  
Website: <http://www.fkip.umsu.ac.id> E-mail: [fkip@umsu.ac.id](mailto:fkip@umsu.ac.id)



**BERITA ACARA BIMBINGAN SKRIPSI**

Perguruan Tinggi : Universitas Muhammadiyah Sumatera Utara  
Fakultas : Keguruan dan Ilmu Pendidikan  
Jurusan/Prog. Studi : Pendidikan Bahasa Inggris  
Nama : Miss Nadia Niyom  
NPM : 1802050124  
Program Studi : Pendidikan Bahasa Inggris  
Judul Skripsi : Students' Difficulties in Online Speaking Learning Process Assisted by Whatsapp Application

Tanggal	Deskripsi Hasil Bimbingan Skripsi	Tanda Tangan
20/11 2022	Abstract Chapter IV: Data & Data Analysis Chapter V: Conclusion	
22/12 2022	Chapter IV: Analyse your data based on theory Chapter V: Write your research's final finding	
30/12 2022	Chapter IV: Do your analysis based on the data collected.	
14/1 - 2023	Final check: review all major or minor revision	
15/1 - 2023	small revision	
25/1 - 2023	Final check: All.	

Diketahui oleh:  
Ketua Prodi

(Pirman Ginting, S.Pd., M.Hum)

Medan, Januari 2023

Dosen Pembimbing

(Rini Ekayati, S.S., M.A.)